

Lower Extremity Order Form



Elvarex[®]

Lymphedema Garments

Date: _____ Patient's Name/ID Code or File #: _____
 Clinic: _____ Address (Optional): _____
 Address: _____ City/State/Zip (Optional): _____
 City/State/Zip: _____ Telephone (Optional): _____
 Date of Birth (mth/yr): _____

Form 57021 must accompany this page

IMPORTANT - All measurements must be recorded in centimeters. Compression classes must be circled. Style must be selected. Please write clearly.

Product # _____

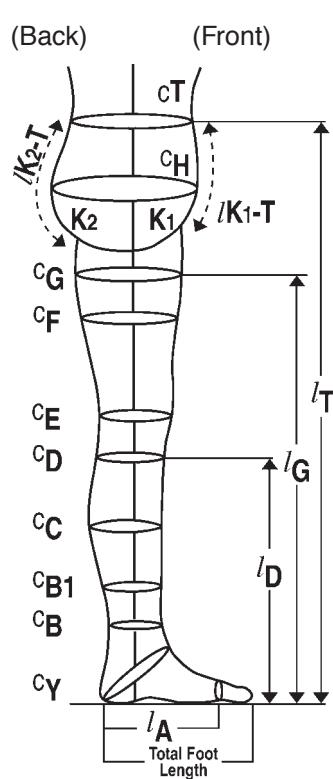

Circum. (c)		Length (l)		Length (l)	
cT		K2-T		lT	
cH		K1-T		lH	
Circumference (c)		Length (l)			
		Left		Right	
cG			lG		
cF			lF		
cE			lE		
cD			lD		
cC			lC		
cB1			lB1		
cB			lB		
cY			lA (medial)		
cA			lA (lateral)		

Class	Qty. L	Qty. R	Qty. Panty	Color
Elvarex 1 (18-21 mmHg*)				BEIGE <input type="checkbox"/>
Elvarex 2 (25-32 mmHg*)				
Elvarex 3 (36-46 mmHg*)				
Elvarex-forte 3F (36-46 mmHg*)				BLACK <input type="checkbox"/>
Elvarex 4 (59-70 mmHg*)				
Elvarex-super 4S (70-90 mmHg*)				Black available for Class 1, 2, 3 only

Styles	
AD Knee High	
AF Mid High	
AG Thigh High	
AGTL Chap Left	
AGTR Chap Right	
AGT Chaps Pair	
AT Pantyhose	
AT Pantyhose, 1 1/2 leg	
GT Biker Shorts	
FG Leg Extension	

Special Styles

Straight open toe _____ cm

Straight closed toe _____ cm

Slant closed toe _____ cm

Fly for men Open pubis

Adjustable waist band

Silicone Band 3 cm 5 cm

top inside

Zippers** Medial (inside) Lateral (outside) Other

Comments: _____

*Design Pressure
 **Zippers can be placed from Y to D or from E to G

BSN-JOBST, Inc.

5825 Carnegie Blvd., Charlotte, NC 28209-4633 U.S.A.

Caution: This product contains natural rubber latex which may cause allergic reactions